

Product Safety Notice: Crosby Shur-Lock Hook



Description of Process:

Tote tanks were being backloaded from a rig to a supply vessel.

Description of Incident:

During the backload of tote tanks from the rig to the supply vessel, a 16mt Crosby hook that was part of the lifting arrangement failed, causing the tote tank that was being lowered onto the deck of the vessel to drop approximately 3ft (1metre), coming to rest on the vessel's deck in an upright orientation.

The crane's MIPEG (crane monitoring system) was checked and the recorded load at the time of the incident was 12mt with a max dynamic weight recorded at 13mt.

The vessel's load handlers were standing a safe distance from the tote tank when it dropped onto the deck, and therefore no injuries were sustained.

The route from the rig's deck to the vessel was barriered off and remained free of personnel for the duration of the operation.

The hook and swivel were supplied and certified as a composite unit.

Weather conditions at the time were very good with wind 18kts, sea state of 1.6 significant and 2.6 maximum.

Good Practice Guidance:

See product safety notice below

IMPORTANT SAFETY NOTICE

USERS OF THE BELOW CROSBY PRODUCT:

S-1326 18/20 mm Shur-Loc Hook with 16t WLL, PN 1004349

With Production Identification Codes (PIC) of 9SB, 9SC, and 9SD as located on the latch

PLEASE CAREFULLY REVIEW AND ACT UPON THE FOLLOWING INSTRUCTIONS.

July 19, 2019

Dear Valued User of Crosby Products:

THE CROSBY GROUP has determined the above listed hook assemblies may have a condition that can reduce the ultimate load capacity. Although the hooks have successfully passed proof load testing at the factory prior to shipment, the hook shank threads may have an issue that is exacerbated by corrosion, and continued use may result in loss of load, property damage, severe injury, or death.

By use of the Production Identification Code (PIC) symbols appearing on the product, we have determined the 18/20mm size of S-1326 Shur-Loc Hooks with PICs 9SB, 9SC, and 9SD shown on the latch may have this condition. See Figure 1 below indicating the position of the PIC on the hook latch. No other PICs are part of this Important Safety Notice.

Please identify any 18/20mm S-1326 Shur-Loc Hooks with PICs 9SB, 9SC, and 9SD on the latch, to have the nut removed for inspection of the latch external threads. These hook assemblies have a removable coiled spring pin nut retention device to allow periodic inspection of the load bearing threads. Below are instructions for nut removal, inspection, and reassembly. If there are no tools or resources available to perform the disassembly and inspection at the hook location, arrangements can be made to have the hooks returned to a Crosby Distributor for inspection. Any hooks with non-conforming threads are to be immediately removed from service and returned to Crosby, through a Crosby Distributor. Hooks with proper threads are acceptable for reassembly and continued service.

If it is determined during inspection that the hook threads are non-conforming, please make arrangements to return the hook for replacement. To return these products, please contact your Crosby Distributor. For more information concerning this Important Safety Notice, contact Technical Support at 1-800-772-1500.

Please inform your customer(s) of this Important Safety Notice, or if you know of other users of the 18/20mm S-1326 Shur-Loc Hooks, please pass this notice on to that user, company, or firm.

We regret the inconvenience this may cause you and your organization, and thank you for your cooperation. We are committed to providing you with the absolute best in Crosby quality.

Sincerely,
THE CROSBY GROUP

Disassembly/Inspection/Assembly Instructions for 18/20mm S-1326 Shur-Loc Hooks

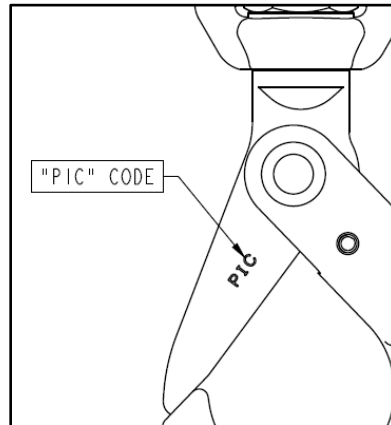

Figure 1 - PIC Location

Disassembly Instructions

1. Using a punch, remove the 6mm coiled spring pin from the hex nut on the shank.
2. Unthread the hex nut from the shank.
3. If necessary, remove the bail and thrust washer from the shank.

Inspection Instructions

1. Inspect the shank thread for non-conforming thread form. The thread form is to be checked by a competent person, and is to conform to M36x4. See images below. Hooks found with non-conforming threads are to be immediately removed from service.
2. Reinstall the coiled spring pin. If the coiled spring pin requires replacement, contact Crosby for a replacement or replace with a 6mm diameter by 50mm long heavy duty coiled steel spring pin per ISO 8748 (Spring pin ISO 8748 – 6 x 50 St).

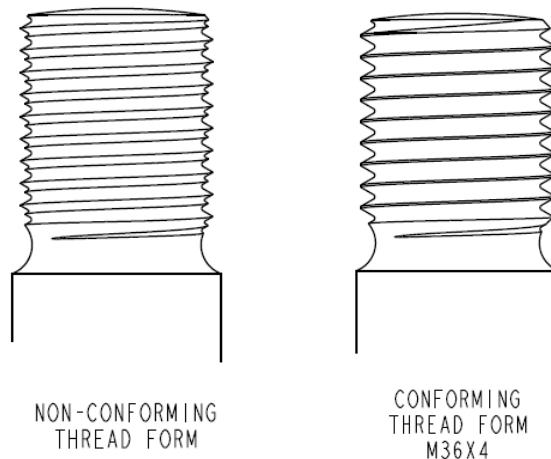

Assembly Instructions

1. Replace the bail and thrust washer onto the shank.
2. Install the nut onto the shank, in the same orientation as it was removed.
3. Thread the nut to the same location, to allow reinstallation of coiled spring pin.
4. Re-install the coiled spring pin into the existing hole in hook and nut.